

Gas density monitor With attached transmitter Model GDM-100-TA



for further approvals see
page 5

Applications

- Gas density monitoring of closed SF₆ tanks
- For indoor and outdoor installation in SF₆ gas-insulated switchgear

Special features

- On-site display with switch contact
- Remote readout (output 4 ... 20 mA, 2-wire), measuring ranges from 0 ... 10 g/litre to 0 ... 80 g/litre
- High electromagnetic compatibility (EMC)
- Hermetically sealed, therefore no influence from atmospheric pressure fluctuation and differences in mounting heights



**Gas density monitor with attached transmitter,
model GDM-100-TA**

Description

The model GDM-100-TA is featured by a attached analog transmitter model GD-10. Through this, the functions of switching and transmission are combined in just one gas density monitor. The combination of a gas density monitor and transmitter in one instrument enables the parallel operation of both instruments with only one process connection, provides additional safety through redundancy and simplifies the installation tasks on the electrical equipment.

The transmitter is electrically compensated in accordance with the non-linear behaviour of SF₆ gas according to the virial equation. This achieves the highest accuracy for the gas density.

The transmitter records the pressure and temperature of the SF₆ gas in the gas tank. The current gas density is ascertained from both measurement parameters by means of an electronic evaluation system. Thermally induced pressure changes are dynamically compensated and do not affect the output signal. The transmitter generates a density-proportional, standardised signal of 4 ... 20 mA.

Recalibration of the zero point is not necessary due to the high long-term stability of the transmitter. The measuring cell ensures a high long-term sealing and is hermetically sealed to prevent leaks and remain independent of atmospheric pressure fluctuations and variations in the mounting height.

Gas density monitor

Nominal size in mm

100

Calibration pressure PE

To customer specification

Accuracy specifications

- $\pm 1\%$ at an ambient temperature of 20 °C [68 °F]
- $\pm 2.5\%$ at ambient temperature -20 ... +60 °C and with calibration pressure in accordance with reference isochore (reference diagram KALI-Chemie AG, Hanover, prepared by Dr. Döring 1979)

Scale range

Vacuum and overpressure range with measuring span of 1.6 ... 25 bar (at an ambient temperature of 20 °C [68 °F] and gaseous phase)

Permissible ambient temperature

Operation: -20 ... +60 °C [-4 ... +140 °F], gaseous phase

Storage: -40 ... +60 °C [-58 ... +140 °F]

Process connection

G ½ B per EN 837, lower mount

Stainless steel, spanner flats 22 mm

Other connections and connection locations on request.

Pressure element

Stainless steel, welded

Gas-tight: Leak rate $\leq 1 \cdot 10^{-8}$ mbar · l / s

Test method: Helium mass spectrometry

Movement

Stainless steel

Bimetal link (temperature compensation)

Dial

Aluminium

Red, yellow, green area as specified in the order

Pointer

Aluminium, black

Case

Selectable versions

Option 1	Stainless steel, with gas filling
Option 2	Stainless steel, with filling liquid

Gas-tight: Leak rate $\leq 1 \cdot 10^{-5}$ mbar · l / s

Window

Selectable versions

Option 1	Laminated safety glass
Option 2	Clear non-splintering plastic

Ring

Bayonet ring, stainless steel, secured by means of 3 welding spots

Permissible air humidity

$\leq 90\%$ r. h. (non-condensing)

Ingress protection

IP65 per IEC/EN 60529

Weight

Case with gas filling: approx. 1.2 kg

Case with fill fluid: approx. 1.6 kg

High-voltage test 100 %

2 kV, 50 Hz, 1 s (wiring against case)

Switch contacts

Electrical connection

Selectable versions

Option 1	Cable socket with compression fitting M20 x 1.5 Wire cross-section max. 2.5 mm ²
Option 2	Plug-in cable box

Number of switch contacts

Selectable versions

Option 1	1 magnetic snap-action contact
Option 2	2 magnetic snap-action contacts
Option 3	3 magnetic snap-action contacts

Switching directions

Selectable versions

Option 1	Falling pressure
Option 2	Rising pressure

Switching functions

Selectable versions

Option 1	Normally open
Option 2	Normally closed
Option 3	Change-over contact (max. 2 switch points)

Circuits

Selectable versions

Option 1	Galvanically connected (not for change-over contact)
Option 2	Galvanically isolated

Switching accuracy

Switch point = calibration pressure P_E : see accuracy specifications

Switch point \neq calibration pressure P_E : Parallel to the reference isochore of the calibration pressure

Max. switching voltage

AC 250 V

Switching power

Case with gas filling: 30 W / 50 VA, max. 1 A

Case with fill fluid: 20 W / 20 VA, max. 1 A

Switch point setting

Selectable versions

Option 1	Secured switch points, not adjustable
Option 2	Adjustable switch points

Material of switch contacts

80 % Ag / 20 % Ni, gold-plated

Further information on magnetic snap-action contacts in data sheet AC 08.01

Gas density sensor

Measuring ranges

Density							
Density range	g/litre	10	16	25	40	60	80
(Pressure range based on 20 °C)	(bar abs.)	(1.64)	(2.59)	(3.97)	(6.16)	(8.87)	(11.33)
Overload safety	bar abs.	14	14	14	29	29	67
Burst pressure sensor element	bar abs.	17	17	17	35	35	80

Intended medium

Pure SF₆ gas

Measuring principle

Piezo-resistive

Output signal

4 ... 20 mA, 2-wire

Permissible max. load R_A

$R_A \leq (U_B - 10 \text{ V}) / 0.02 \text{ A}$ with R_A in Ohms and U_B in Volts

Power supply U_B

DC 10 ... 30 V

Accuracy specifications

■ Point of optimal density:

- 40 °C: 3 % of span
- 20 °C: 1 % of span
- 60 °C: 2.3 % of span

■ Start and end of the measuring range:

- 40 °C: 4 % of span
- 20 °C: 2 % of span
- 60 °C: 3.3 % of span

Stability per year

≤ 0.3 % of span (at reference conditions)

Electromagnetic compatibility (EMC) to IEC 61000-4

IEC 61000-4-2 (ESD): test level 4 (8 kV)

IEC 61000-4-3 (Field): test level 3 (10 V/m)

IEC 61000-4-4 (Burst): test level X (±2 kV)

IEC 61000-4-5 (Surge): test level 2 (±1 kV)

IEC 61000-4-6 (Conducted RFI): test level 3 (10 V)

High-voltage strength

DC 750 V (electrical connections against case)

Permissible ambient temperature

Operation: -40 ... +60 °C [-40 ... +140 °F], gaseous phase

Storage: -40 ... +80 °C [-40 ... +176 °F]

Electrical connection

Angular connector (2-pin), IP67

Electrical safety

Protection against reverse polarity and overvoltage

Materials

Wetted parts: Stainless steel

Case, terminal enclosure: Stainless steel

Internal pressure transmission medium

Synthetic oil

Dimensions in mm

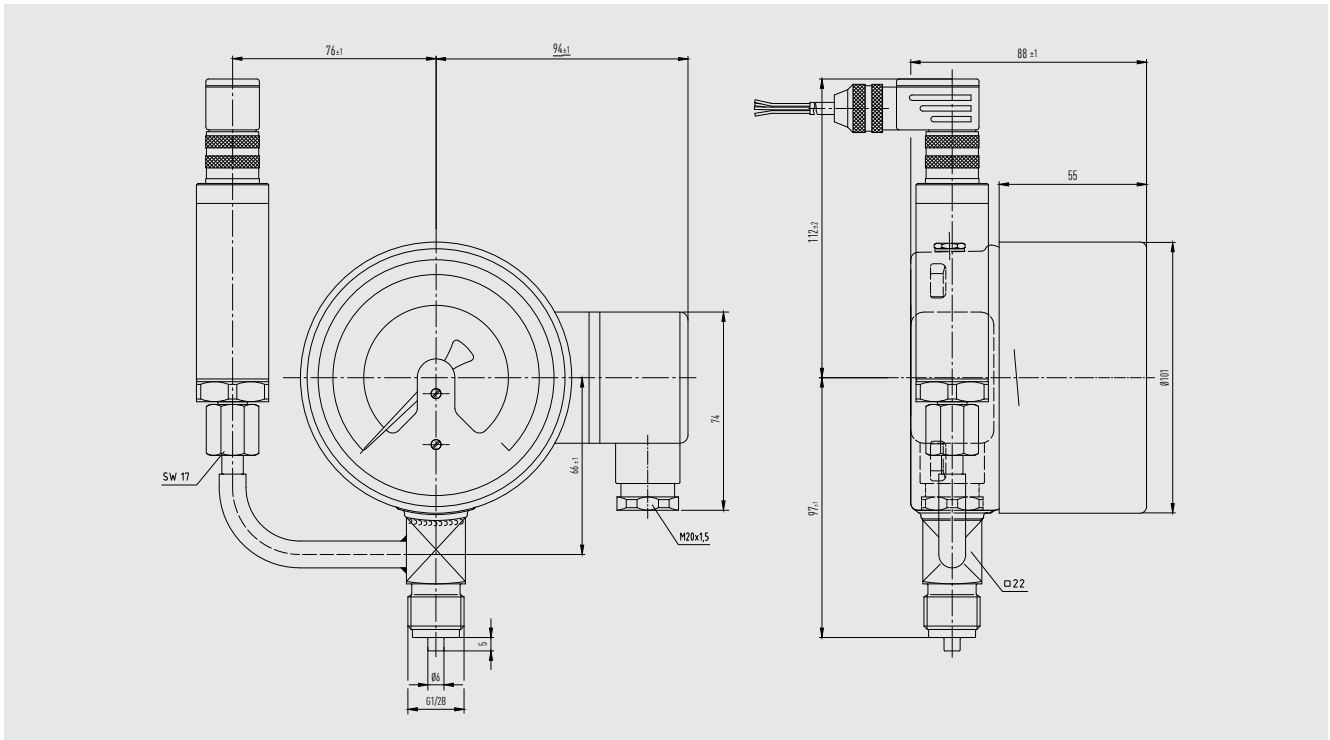

Approvals

Logo	Description	Country
CE	EU declaration of conformity <ul style="list-style-type: none"> ■ EMC directive ■ Pressure equipment directive ■ Low voltage directive 	European Union
EAC	EAC <ul style="list-style-type: none"> ■ EMC directive ■ Pressure equipment directive ■ Low voltage directive ■ Machinery directive ■ Gas appliances directive 	Eurasian Economic Community

Ordering information

Sealing range / Pressure unit / Process connection / Electrical connection / Filling pressure / Switch configuration / Gas mixture

© 01/2019 WIKA Alexander Wiegand SE & Co. KG, all rights reserved.
 The specifications given in this document represent the state of engineering at the time of publishing.
 We reserve the right to make modifications to the specifications and materials.

